

P5SS - Precision Slide Tables

The Precision Slide Table P5SS is a pneumatic actuator, operated by two cylinders mounted in parallel for moving loads fitted on its mobile carriage or on its front plate quickly and accurately. Optional end of stroke adjusters offer precise adjustment even when the slide table is pressurised.



- High precision
- Bores Ø6, 8, 12, 16, 20 and 25mm
- Combination of dual bore cylinder and linear rail
- Magnetic piston standard
- Rubber bumper standard
- Optional stroke adjusters
- Optional shock absorbers bores Ø8 - 25mm

Operating Information

Pressure range:	1.5 to 7 bar
Temperature range:	-5° to 60° C
Filtration requirements:	
Air filtration	40 micron or better
Air lubrication	Not necessary*
Air humidity	Low moisture content (dry)

* Addition of lubrication will greatly increase service life

For more information see www.parker.com/euro_pneumatic

Ordering Information: P5SS

Ø6mm bore

Stroke (mm)	Order code
10	P5SS-006DSG010B
20	P5SS-006DSG020B
30	P5SS-006DSG030B
40	P5SS-006DSG040B
50	P5SS-006DSG050B

Ø12mm bore

Stroke (mm)	Order code
10	P5SS-012DSG010B
20	P5SS-012DSG020B
30	P5SS-012DSG030B
40	P5SS-012DSG040B
50	P5SS-012DSG050B
75	P5SS-012DSG075B
100	P5SS-012DSG100B

Ø20mm bore

Stroke (mm)	Order code
10	P5SS-020DSG010B
20	P5SS-020DSG020B
30	P5SS-020DSG030B
40	P5SS-020DSG040B
50	P5SS-020DSG050B
75	P5SS-020DSG075B
100	P5SS-020DSG100B
125	P5SS-020DSG125B

Ø8mm bore

Stroke (mm)	Order code
10	P5SS-008DSG010B
20	P5SS-008DSG020B
30	P5SS-008DSG030B
40	P5SS-008DSG040B
50	P5SS-008DSG050B
75	P5SS-008DSG075B

Ø16mm bore

Stroke (mm)	Order code
10	P5SS-016DSG010B
20	P5SS-016DSG020B
30	P5SS-016DSG030B
40	P5SS-016DSG040B
50	P5SS-016DSG050B
75	P5SS-016DSG075B
100	P5SS-016DSG100B
125	P5SS-016DSG125B

Ø25mm bore

Stroke (mm)	Order code
10	P5SS-025DSG010B
20	P5SS-025DSG020B
30	P5SS-025DSG030B
40	P5SS-025DSG040B
50	P5SS-025DSG050B
75	P5SS-025DSG075B
100	P5SS-025DSG100B
125	P5SS-025DSG125B
150	P5SS-025DSG150B

Sensors - Series P8S-E

Magnetic Sensor



PNP

NPN

Reed

M8 - Snap in



0.165 m PUR cable with M8 connector

P8S-EPSUS

P8S-ENSUS

P8S-ERSUS

Flying lead



2 m PUR cable

P8S-EPFXS

P8S-ENFXS

P8S-ERFXS

Precision Slide Table Ø6 - Dimensions (mm)

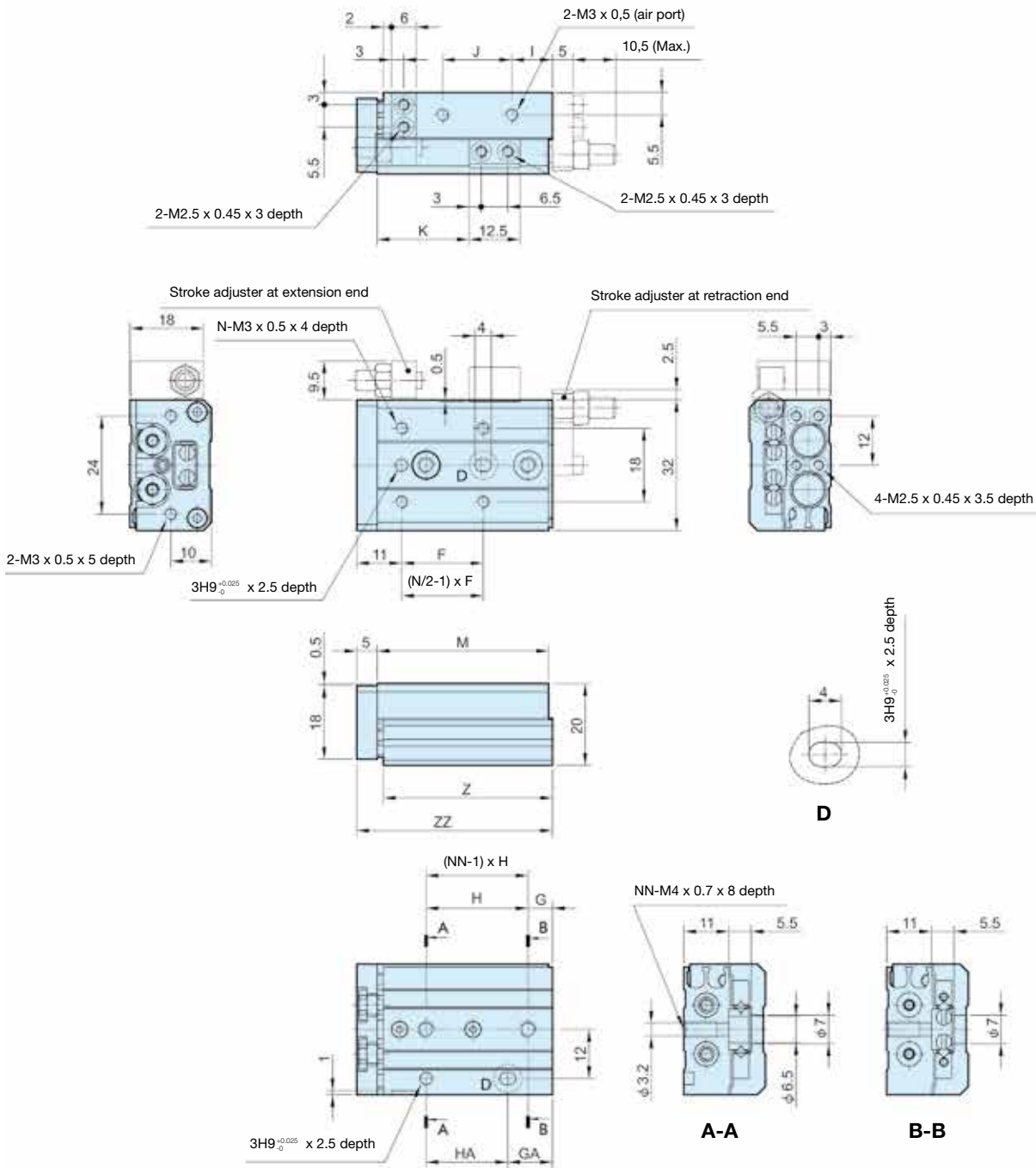

Stroke	F	G	GA	H	HA	I	J	K	M	N	NN	Z	ZZ
10	20	6	11	25	20	10	17	22,5	42	4	2	41,5	48
20	30	6	21	35	20	10	27	32,5	52	4	2	51,5	58
30	20	11	31	20	20	7	40	42,5	62	6	3	61,5	68
40	28	13	43	30	30	19	50	52,5	84	6	3	83,5	90
50	38	17	41	24	48	25	60	62,5	100	6	4	99,5	106

Precision Slide Table Ø8 - Dimensions (mm)

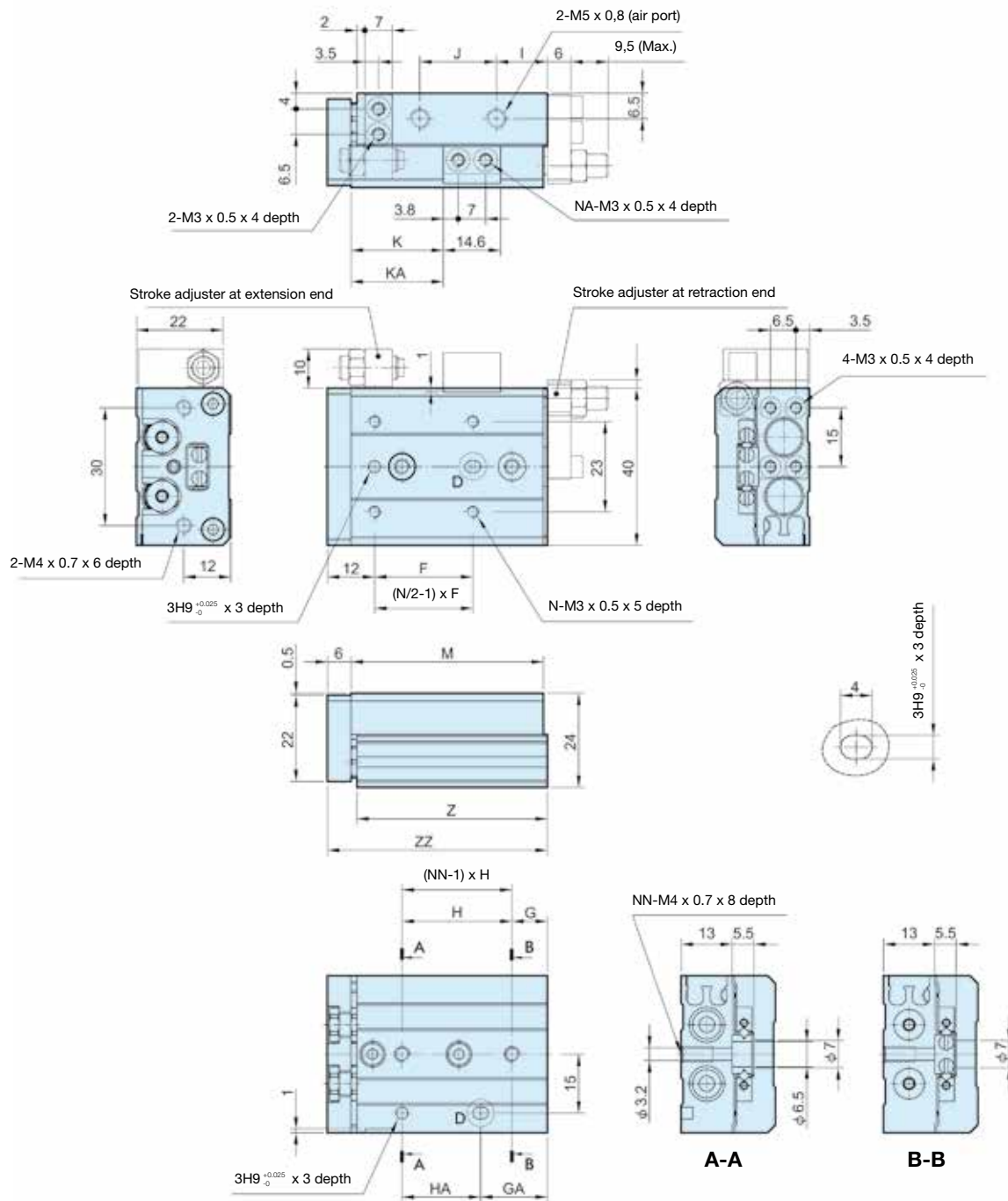

Stroke	F	G	GA	H	HA	I	J	K	KA	M	N	NA	NN	Z	ZZ
10	25	9	17	28	20	13	19,5	23,5	-	49	4	2	2	48,5	56
20	25	12	12	30	30	8,5	29	33,5	-	54	4	2	2	53,5	61
30	40	13	33	20	20	9,5	39	43,5	-	65	4	2	3	64,5	72
40	50	15	43	28	28	10,5	56	53,5	-	83	4	2	3	82,5	90
50	38	20	43	23	46	24,5	60	63,5	82,5	101	6	4	4	100,5	108
75	50	27	83	28	56	38,5	96	88,5	132,5	151	6	4	5	105,5	158

Precision Slide Table Ø12 - Dimensions (mm)

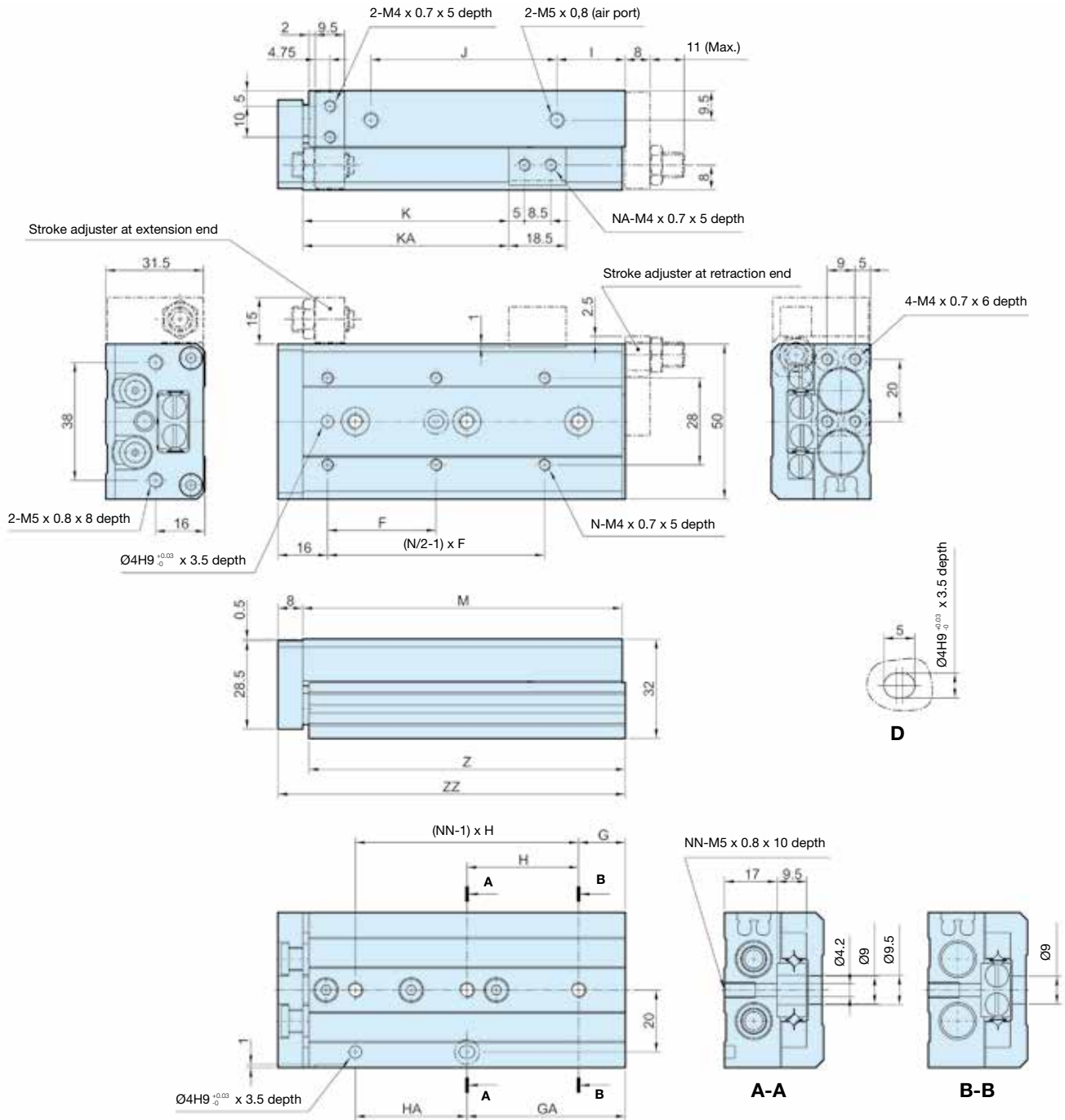

Stroke	F	G	GA	H	HA	I	J	K	KA	M	N	NA	NN	Z	ZZ
10	35	15	15	40	40	10	40	26,5	-	71	4	2	2	70	80
20	35	15	15	40	40	10	40	36,5	-	71	4	2	2	70	80
30	35	15	15	40	40	10	40	46,5	-	71	4	2	2	70	80
40	50	17	42	25	25	10	52	56,5	-	83	4	2	3	82	92
50	35	15	51	36	36	22	60	66,5	-	103	6	2	3	102	112
75	55	25	61	36	72	43	85	91,5	125,5	149	6	4	4	148	158
100	65	35	111	38	76	52	130	116,5	179,5	203	6	4	5	202	212

Precision Slide Table Ø16 - Dimensions (mm)

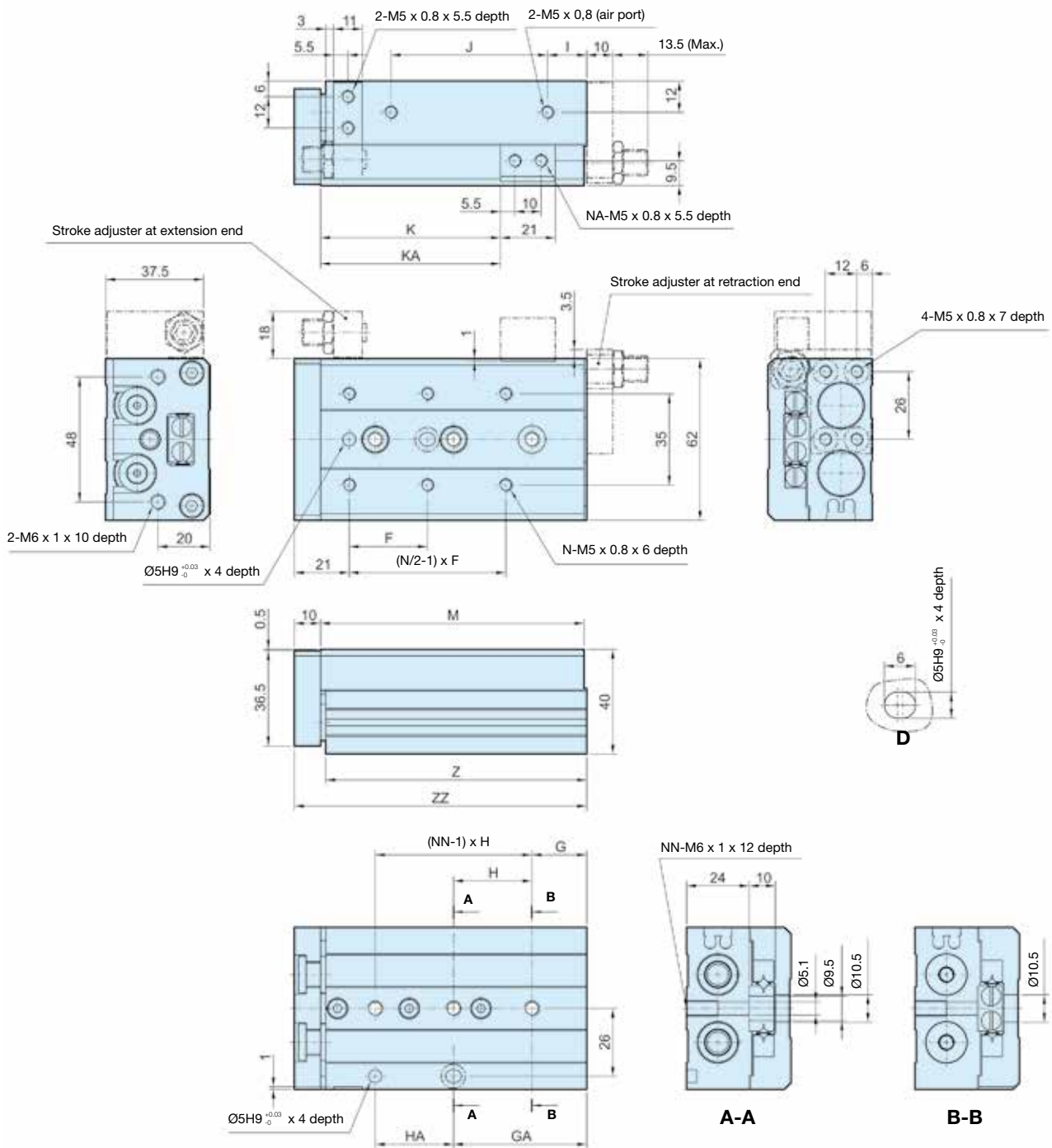

Stroke	F	G	GA	H	HA	I	J	K	KA	M	N	NA	NN	Z	ZZ
10	35	16	16	40	40	10	40	29	-	76	4	2	2	75	87
20	35	16	16	40	40	10	40	39	-	76	4	2	2	75	87
30	35	16	16	40	40	10	40	49	-	76	4	2	2	75	87
40	40	16	16	50	50	10	50	59	-	86	4	2	2	85	97
50	30	21	51	30	30	15	60	69	-	101	6	2	3	100	112
75	55	26	61	35	70	40	85	94	125	151	6	4	4	150	162
100	65	39	109	35	70	55	118	119	173	199	6	4	5	198	210
125	70	19	159	35	70	68	155	144	223	249	8	4	7	248	260

Precision Slide Table Ø20 - Dimensions (mm)

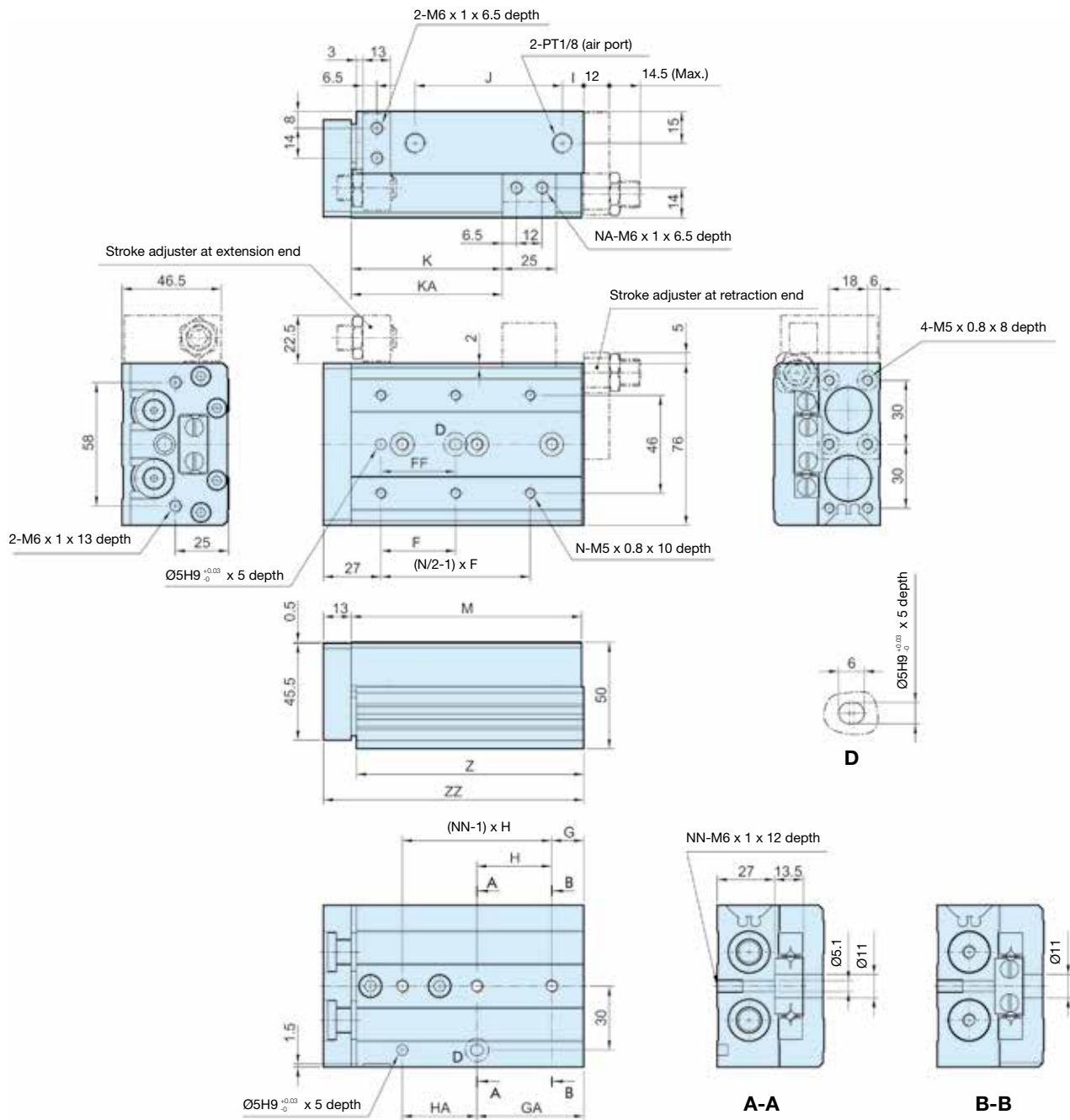

Stroke	F	FF	G	GA	H	HA	I	J	K	KA	M	N	NA	NN	Z	ZZ
10	50	40	15	25	45	35	10	44	31	-	83	4	2	2	81,5	97
20	50	40	15	25	45	35	10	44	41	-	83	4	2	2	81,5	97
30	50	40	15	25	45	35	10	44	51	-	83	4	2	2	81,5	97
40	60	50	15	35	55	35	10	54	61	-	93	4	2	2	91,5	107
50	35	35	15	50	35	35	10	69	71	-	108	6	2	3	106,5	122
75	60	60	19	54	35	70	10	108	96	-	147	6	2	4	145,5	161
100	70	70	37	107	35	70	58	113	121	169	200	6	4	5	198,5	214
125	70	70	41	155	38	76	70	155	146	223	254	8	4	6	252,5	268
150	80	80	19	195	44	88	87	190	171	275	306	8	4	7	304,5	320

Precision Slide Table Ø25 - Dimensions (mm)

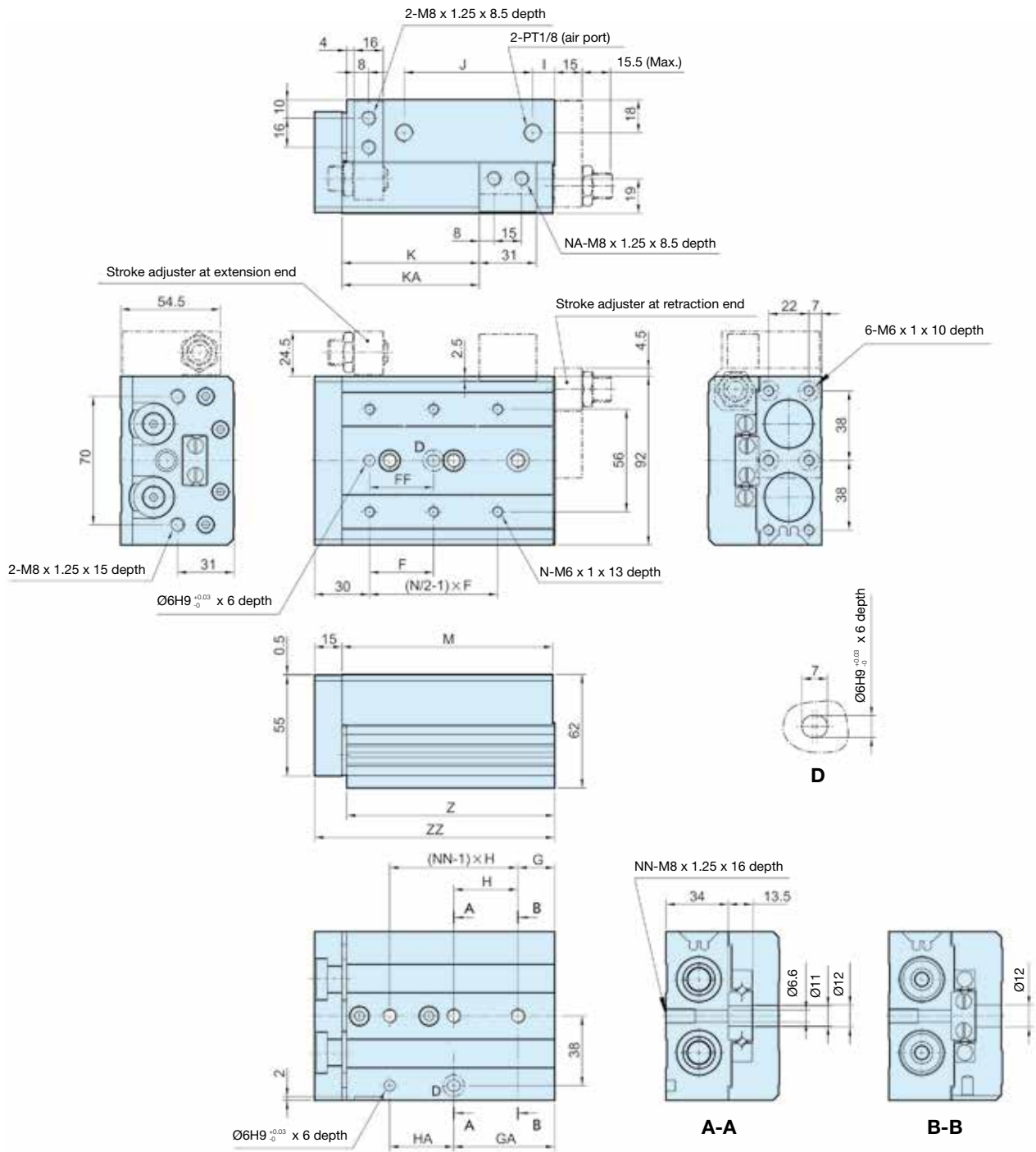

Stroke	F	FF	G	GA	H	HA	I	J	K	KA	M	N	NA	NN	Z	ZZ
10	50	40	22	22	45	45	12	47	35	-	92	4	2	2	90,5	108
20	50	40	22	22	45	45	12	47	45	-	92	4	2	2	90,5	108
30	50	40	22	22	45	45	12	47	55	-	92	4	2	2	90,5	108
40	60	50	22	22	55	55	12	57	65	-	102	4	2	2	100,5	118
50	35	35	20	55	35	35	12	70	75	-	115	6	2	3	113,5	131
75	60	60	26	61	35	70	33	90	100	-	156	6	2	4	154,5	172
100	70	70	32	102	35	70	50	114	125	162	197	6	4	5	195,5	213
125	75	75	40	154	38	76	67	155	150	218	255	8	4	6	253,5	271
150	80	80	30	190	40	80	82	180	175	258	295	8	4	7	293,5	311

Accessories Ø6 - Ø25

Stroke adjuster at extension end:

Mounted to body

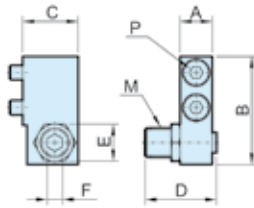

Mounted to table

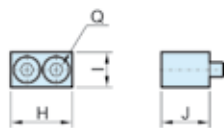

Bore mm	Order code	Adjustable stroke range (mm)	Mounted to body							Mounted to table				
			A	B	C	D	E	F	M	P*	H	I	J	Q*
6	P5SS-006-EA-05	5	6	17,8	10,5	16,5	7	2,5	M5 x 0.8	M2.5x10	12,5	6	8,5	M2.5 x 8
	P5SS-006-EA-15	15												
8	P5SS-008-EA-05	5	7	21,5	11	16,5	8	3	M6 x 1	M3 x 10	14,6	7	10	M3 x 10
	P5SS-008-EA-15	15				26,5								
	P5SS-008-EA-25	25				36,5								
12	P5SS-012-EA-05	5	9,5	31	16	20	11	4	M8 x 1	M4 x 16	18,5	10	13	M4 x 12
	P5SS-012-EA-15	15				30								
	P5SS-012-EA-25	25				40								
16	P5SS-016-EA-05	5	11	37	19	24,5	14	5	M10 x 1	M5 x 16	21	12	16,5	M5 x 16
	P5SS-016-EA-15	15				34,5								
	P5SS-016-EA-25	25				44,5								
20	P5SS-020-EA-05	5	13	45,5	24	27,5	17	6	M12 x 1.25	M6 x 20	25	13	21	M6 x 20
	P5SS-020-EA-15	15				37,5								
	P5SS-020-EA-25	25				47,5								
25	P5SS-025-EA-05	5	16	53,5	26,5	32,5	19	6	M14 x 1.5	M8 x 25	31	17	25,5	M8 x 25
	P5SS-025-EA-15	15				42,5								
	P5SS-025-EA-25	25				52,5								

* Size of hexagon socket head cap screws

Stroke adjuster at retraction end:

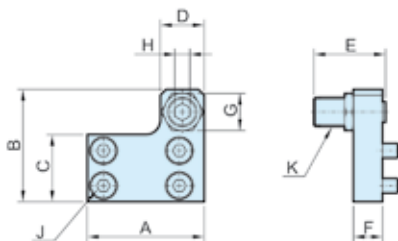

P5SS-006
P5SS-008

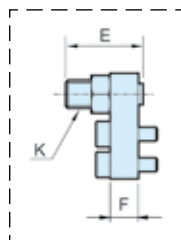

Bore mm	Order code	Adjustable stroke range (mm)	A	B	C	D	E	F	G	H	J*	K
			6	P5SS-006-RA-05	5	21	19	10,5	8	16,5	5	7
P5SS-006-RA-15	15	26,5										
8	P5SS-008-RA-05	5	25	22,5	12,5	9	16,5	6	8	3	M3 x 10	M6 x 1
	P5SS-008-RA-15	15					26,5					
	P5SS-008-RA-25	25					36,5					
12	P5SS-012-RA-05	5	32	31	18,5	13	20	8	12	4	M4 x 8	M8 x 1
	P5SS-012-RA-15	15					30					
	P5SS-012-RA-25	25					40					
16	P5SS-016-RA-05	5	40	38,5	23	15	24,5	10	14	5	M5 x 10	M10 x 1
	P5SS-016-RA-15	15					34,5					
	P5SS-016-RA-25	25					44,5					
20	P5SS-020-RA-05	5	50	48	29	21	27,5	12	17	6	M5 x 12	M12 x 1.25
	P5SS-020-RA-15	15					37,5					
	P5SS-020-RA-25	25					47,5					
25	P5SS-025-RA-05	5	60	58	35	23	32,5	15	19	6	M6 x 16	M14 x 1.5
	P5SS-025-RA-15	15					42,5					
	P5SS-025-RA-25	25					52,5					

* Size of hexagon socket head cap screws

Accessories Ø8 - Ø25

Shock absorber at extension end:

Mounted to body

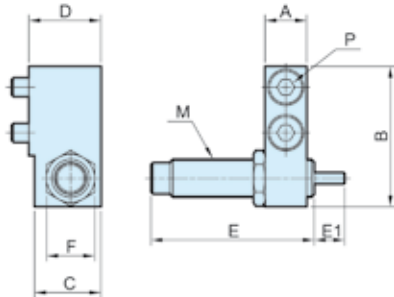

Mounted to table

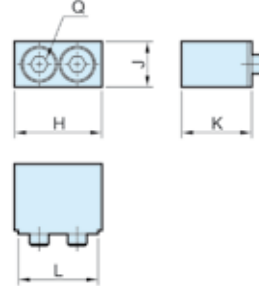

Bore mm	Order code	Mounted to body									Mounted to table				
		A	B	C	D	E	E1	F	M	P*	H	J	K	L	Q*
8	P5SS-008-ESK	7	23	14	15,5	40,6	6	11	M8 x 1	M3 x 16	16,6	7	15,5	14,6	M3 x 16
12	P5SS-012-ESK	9,5	31	14,5	16	40,6	6	11	M8 x 1	M4 x 16	20,5	10	15	18,5	M4 x 12
16	P5SS-016-ESK	11	37	17,5	19	47	7	12,7	M10 x 1	M5 x 16	23	12	18,5	21	M5 x 16
20	P5SS-020-ESK	13	45,5	23,5	26	67	12	19	M14 x 1.5	M6 x 25	27	13	25,5	25	M6 x 25
25	P5SS-025-ESK	16	53,5	23,5	26,5	67	12	19	M14 x 1.5	M8 x 25	33	17	25,5	31	M8 x 25

* Size of hexagon socket head cap screws

Shock absorber at retraction end:

Mounted to body

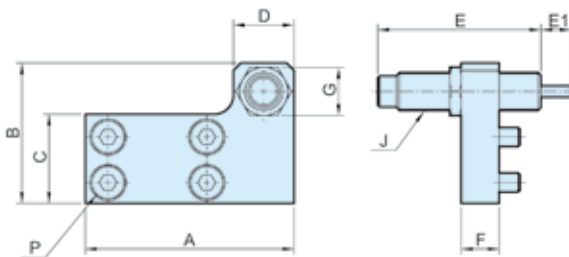

Mounted to table

P5SS-008

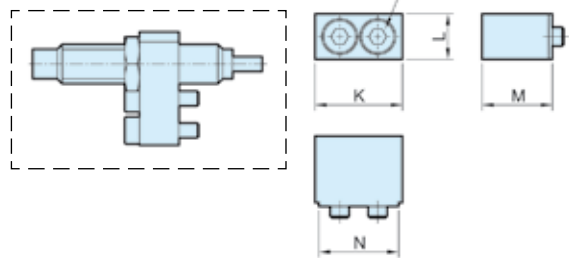

Bore mm	Order code	Mounted to body									Mounted to table					
		A	B	C	D	E	E1	F	G	J	P*	K	L	M	N	Q*
8	P5SS-008-RSK	38	23	12,5	14	40,6	6	8	12	M8 x 1	M3 x 12	16,6	7	15,5	14,6	M3 x 16
12	P5SS-012-RSK	45	31	18	14	40,6	6	8	11	M8 x 1	M4 x 8	20,5	10	15	18,5	M4 x 12
16	P5SS-016-RSK	55	37	23,5	16	47	7	10	12,7	M10 x 1	M5 x 10	23	12	18,5	21	M5 x 16
20	P5SS-020-RSK	70	47	29	23	67	12	12	19	M14 x 1.5	M5 x 12	27	13	25,5	25	M6 x 25
25	P5SS-025-RSK	80	54	35	23	67	12	12	19	M14 x 1.5	M6 x 16	33	17	25,5	31	M8 x 25

* Size of hexagon socket head cap screws